



Configuring the Dell DL4X00 Backup and Recovery Appliance with Fibre Channel Storage

Dell Technical Marketing
October 2014

Revisions

Date	Description
October 2014	Initial release

THIS WHITE PAPER IS FOR INFORMATIONAL PURPOSES ONLY, AND MAY CONTAIN TYPOGRAPHICAL ERRORS AND TECHNICAL INACCURACIES. THE CONTENT IS PROVIDED AS IS, WITHOUT EXPRESS OR IMPLIED WARRANTIES OF ANY KIND.

© 2014 Dell Inc. All rights reserved. Reproduction of this material in any manner whatsoever without the express written permission of Dell Inc. is strictly forbidden. For more information, contact Dell.

PRODUCT WARRANTIES APPLICABLE TO THE DELL PRODUCTS DESCRIBED IN THIS DOCUMENT MAY BE FOUND AT: <http://www.dell.com/learn/us/en/19/terms-of-sale-commercial-and-public-sector> Performance of network reference architectures discussed in this document may vary with differing deployment conditions, network loads, and the like. Third party products may be included in reference architectures for the convenience of the reader. Inclusion of such third party products does not necessarily constitute Dell's recommendation of those products. Please consult your Dell representative for additional information.

Trademarks used in this text:

Dell™, the Dell logo, PowerVault™, AppAssure™, and Compellent™ are trademarks of Dell Inc. Other Dell trademarks may be used in this document. Brocade® is a registered trademark of Brocade Communications Systems, Inc. Emulex is a registered trademark of Emulex Corporation. Qlogic® is a registered trademark of QLogic Corporation. Other trademarks and trade names may be used in this document to refer to either the entities claiming the marks and/or names or their products and are the property of their respective owners. Dell disclaims proprietary interest in the marks and names of others.



Table of contents

Revisions	2
Executive summary	4
1 Introduction	5
2 Prerequisites & Assumptions	6
2.1.1 Technical Resources	6
3 Process for DL4X00 & Fibre Channel Integration.....	7
3.1.1 Connect the DL4X00 fibre channel HBA to a SAN switch	7
3.1.2 Install the QLogic or Emulex HBA management software on the DL4X00	7
3.1.3 Install the Fibre Channel Storage Array Multi-Path Software on the DL4X00.....	7
3.1.4 Fibre Channel Zoning	9
3.1.5 Create a Fibre Channel LUN to be assigned and used as a DL4X00 repository	13
3.1.6 Mount the newly assigned fibre channel storage LUN to the DL4X00.....	16
3.1.7 Configure the DL4X00 fibre channel storage as a backup repository	19



Executive summary

Data backup and recovery solutions continue to challenge IT administrators. Traditional data backup and recovery technologies are limited in ability to protect both physical and virtual hybrid environments and struggle to cost effectively meet the demands of data growth. To reduce RPO, RTO and SLA's demanded by today's business environments, IT administrators are looking to next-generation data protection technologies to reduce costs and management complexity while meeting user demands for performance and availability.

The Dell DL4X00 is a 1U turnkey backup and recovery appliance powered by award-winning AppAssure backup and recovery software. The DL4X00 protects both physical and virtual servers, nearly eliminates backup windows, recovers applications within minutes, and guarantees recoverability.

In addition to backup and recovery, the DL4X00 offers disaster recovery and enterprise capabilities such as remote replication, encryption, compression, deduplication and support for up to 4 standby virtual machines to be used for near instantaneous server recovery. The DL4X00 appliance is built and designed to be deployed within minutes and is easy to manage.



1 Introduction

This white paper provides guidance for implementing a DL4X00 in fibre channel storage environments. The DL4X00 high-capacity edition can be ordered with a fibre channel allowing the Core repository to be installed on a fibre channel storage array. Once integrated, the DL4X00 protects servers, applications and its data over the LAN in a highly efficient manner utilizing the AppAssure backup and recovery engine.

The DL4X00 can be configured in many fibre channel switch and storage array environments that include Compellent and MD3600f storage arrays and Brocade switches that are supported by Dell. In this white paper, a pair of Brocade 6505 switches and a Dell PowerVault MD3600f storage array are used as an example. The steps and examples for fibre channel integration apply to the DL4X00 family of appliances as well.

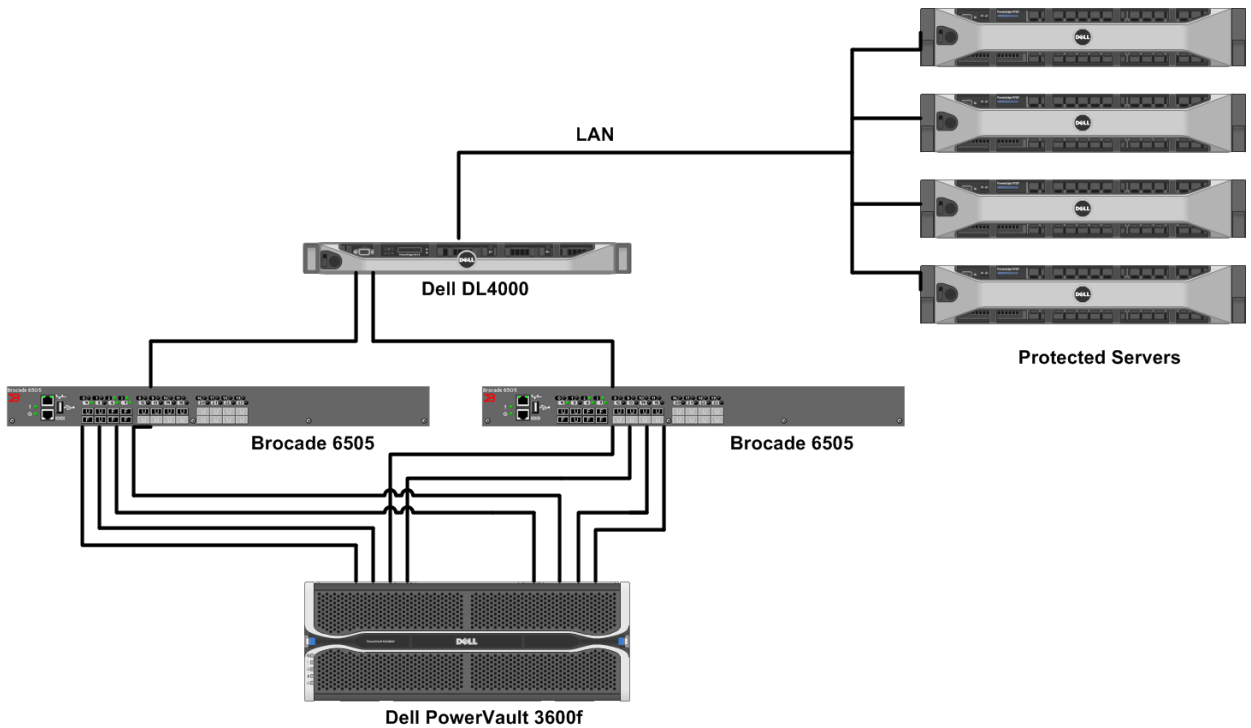

2 Prerequisites & Assumptions

- The DL4X00 is set up and configured within the existing network environment.

Note: Automatically provision the DL4X00 using the AppAssure Appliance Configuration Wizard, then manually configure the DL4X00 fibre channel repository.

- The MD3600f SAN storage array is set up, configured and operational.
- Dell Pro Services performs steps 1-7 below. Remote Installation Services performs the 8th integration process step.

2.1.1 Technical Resources

The following table shows additional documentation available for reference.

Hardware Component	Software / Document or Resource Title	Location
DL4X00	DL4X00 Manuals and Documentation	Product Support
AppAssure	Knowledge Article 118407	Support.software.dell.com
	Knowledge Article 119910	Support.software.dell.com
QLogic 2562 HBA	QConvergeConsole	driverdownloads.qlogic.com
Emulex LPE 12002 HBA	OneCommand Manager	Emulex.com/products
Brocade 6505	EZSwitchSetup Administrator's Guide	Product Support
MD3600f	<i>Dell PowerVault MD3600f and MD3620F Storage Arrays Deployment Guide</i>	Product Support
	<i>Configuring Fibre Channel With Dell MD3600f/3620f/MD3660f Series Storage Arrays</i>	Product Support



3 Process for DL4X00 & Fibre Channel Integration

The procedure to integrate and use fibre channel storage as a DL4X00 backup repository follow these general steps:

1. Connect the DL4X00 fibre channel HBA to a SAN switch.
2. Install the QLogic or Emulex HBA management software on the DL4X00.
3. Install the storage array multi path software on the DL4X00.
4. Inventory the DL4X00 and storage array WWNs (World Wide Names).
5. Zone the fibre channel fabric to allow the DL4X00 to access the storage array.
6. Create a fibre channel LUN to be assigned and used as a DL4X00 repository.
7. Mount the fibre channel storage LUN to the DL4X00,
8. Configure the DL4X00 fibre channel storage as a backup repository.

3.1.1 Connect the DL4X00 fibre channel HBA to a SAN switch

Refer to the [Configuring Fibre Channel with Dell MD3600f/3620f/MD3660f Series Storage Arrays Guide](#) found on dell.com/support. Consult with your SAN administrator for guidance connecting any fibre channel device into your fabric.

3.1.2 Install the QLogic or Emulex HBA management software on the DL4X00

Download [QLogic QConvergeConsole](#) or [Emulex OneCommand Manager](#) HBA management software and install it on the DL4X00.

3.1.3 Install the Fibre Channel Storage Array Multi-Path Software on the DL4X00

The MD3600f provides a DSM for the DL4X00 MPIO driver. The DSM gives the DL4X00 storage array specific information needed to optimize connectivity such as IO-path load balancing and failover.

To load the MD3600f DSM on the DL4X00:

1. Insert the PowerVault MD series resource media and install the MDSM software.
2. Select **Host** to install the Host Core software on the DL4X00.

NOTE: Installation of the DL4X00 DSM (multi-path driver) will enable Microsoft MPIO as necessary.



3. (Optional) Select **Management Station** to install the MDSM management software on the DL4X00. MDSM provides management, configuration and monitoring of the storage array.

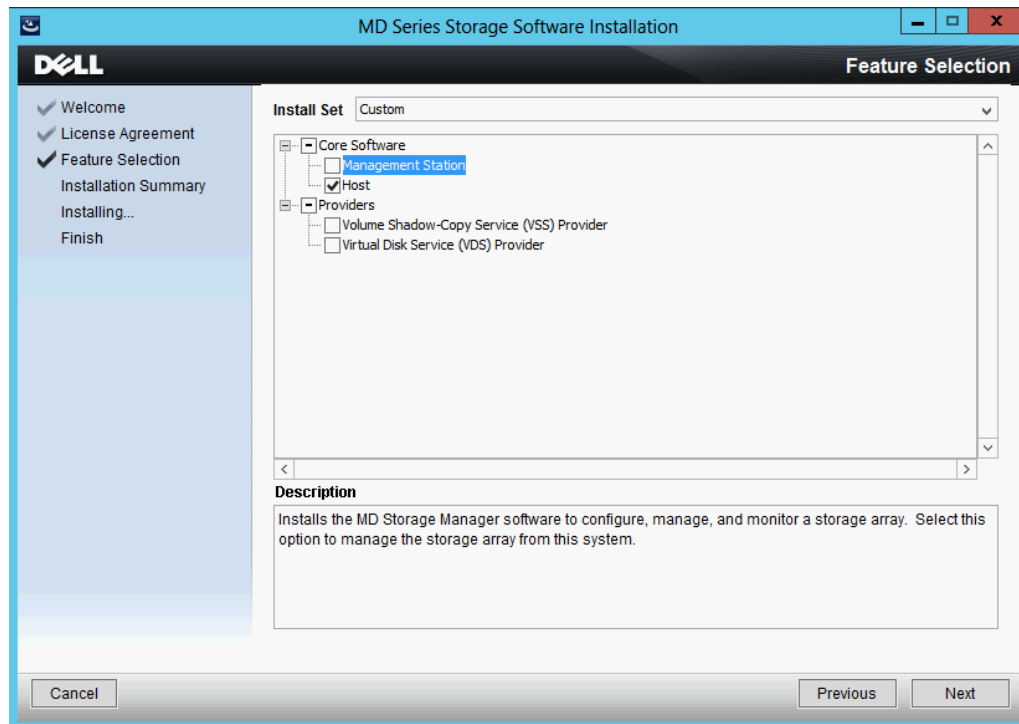

For additional details to these steps, refer to the [Dell PowerVault MD3600f and MD3620F Storage Arrays Deployment Guide](#) on dell.com/support.

3.1.4 Fibre Channel Zoning

3.1.4.1 Inventory the DL4X00 and Storage Array WWNs

To prepare for zoning, create an inventory of port WWNs by identifying and documenting the WWNs of the DL4X00 HBA ports. In this example, a DL4X00 hosts a QLogic 2562 Dual Port 8GB Optical Fibre Channel Low Profile HBA.

1. Within the DL4X00, launch QConvergeConsole.
2. Within the console, select Port 1 and Port 2 and inventory their port WWNs.

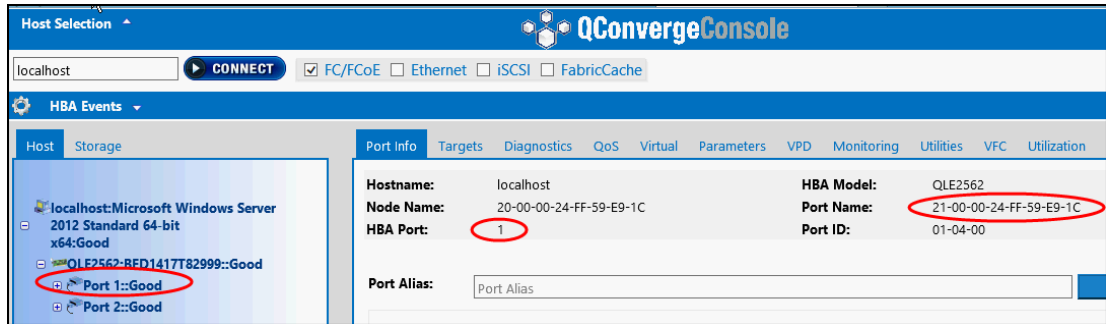

QLogic 2562 HBA	
Port 1	Port 2
21-00-00-24-FF-59-e9-1C	21-00-00-24-FF-59-E9-1D

Identify and document the WWNs of the MD3600f storage array. The MD3600f has four fibre channel ports on both controller-1 and controller-2.



3. Within MSDM, select the **Summary** tab, then select **View Storage array Profile**. Select the **Hardware** tab, then the **RAID Controller Modules** tab. Scroll down and catalog the port WWNs of each controller.

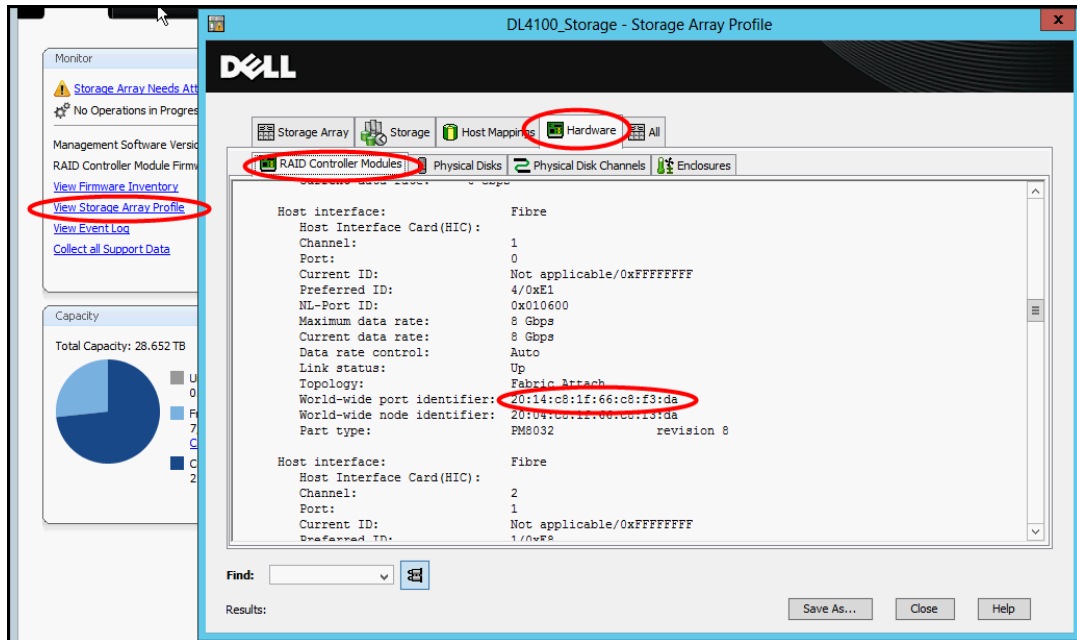

	Controller-0	Controller-1
Port-0	20:14:c8:1f:66:c8:f3:da	20:15:c8:1f:66:c8:f3:da
Port-1	20:24:c8:1f:66:c8:f3:da	20:25:c8:1f:66:c8:f3:da
Port-2	20:34:c8:1f:66:c8:f3:da	20:35:c8:1f:66:c8:f3:da
Port-3	20:44:c8:1f:66:c8:f3:da	20:45:c8:1f:66:c8:f3:da

3.1.4.2 Zone the fibre channel fabric to allow the DL4X00 to access the storage array

Zoning logically partitions a fibre channel SAN fabric to allow devices to access each other. There are many methods and approaches to zoning, thus consult your SAN administrator for zoning practices used in your environment. The following steps describe single initiator and target zoning using a Brocade 6505 fibre channel switch. A zone created in this example use port WWNs to allow the DL4X00 to access only the MD3600f.



Eight port-based single-initiator zones are created. Four zones are created on fibre channel switch-1 and four zones are created on switch-2.

1. Launch the Brocade switch-1 management GUI.
2. Identify the DL4X00 initiator WWN and the four MD3600f target WWNs connected to the switch. The following four zones will be created in Brocade switch-1:

Initiator (DL4X00 QLogic WWN)	Target (MD3600f controller WWN)
21:00:00:24:ff:59:e9:1c	20:24:c8:1f:66:c8:f3:da
	20:25:c8:1f:66:c8:f3:da
	20:34:c8:1f:66:c8:f3:da
	20:35:c8:1f:66:c8:f3:da

3. Create the four zones in switch-1.
 - a. Select **New Zone** and enter a zone name. DL_DR_Zone1 was used in this example.
 - b. Highlight the QLogic initiator and press the arrow button to add it as a new zone member.
 - c. Highlight one of the MD3600f target ports and press the arrow button to add it as a new zone member.

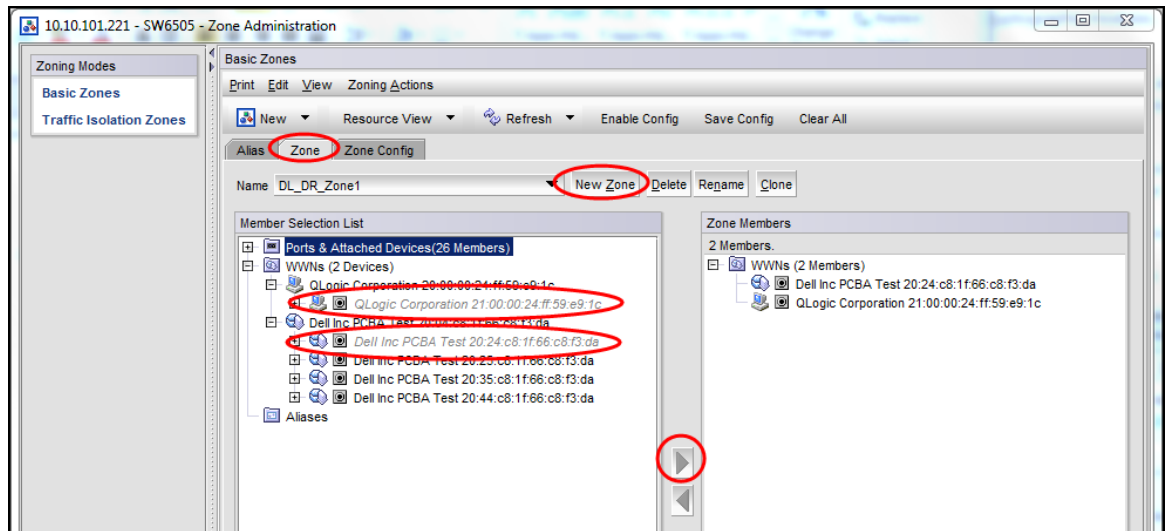

- d. A new zone has been created. Repeat steps 1- 3 to create the remaining three zones for switch-1.



4. Add the four newly created zones into a Brocade zone configuration and enable it.
 - a. Select the **Zone Config** tab.
 - b. Select **New Zone Config** and enter a zone configuration name. DL_MD3000config was used in this example.
 - c. Highlight the four zones created in step 3, then press the arrow key to add them in the **Zone Config Members** list.
 - d. Save the new zone configuration by selecting **Save Config**.
 - e. Enable the zone configuration by selecting **Enable Config**.

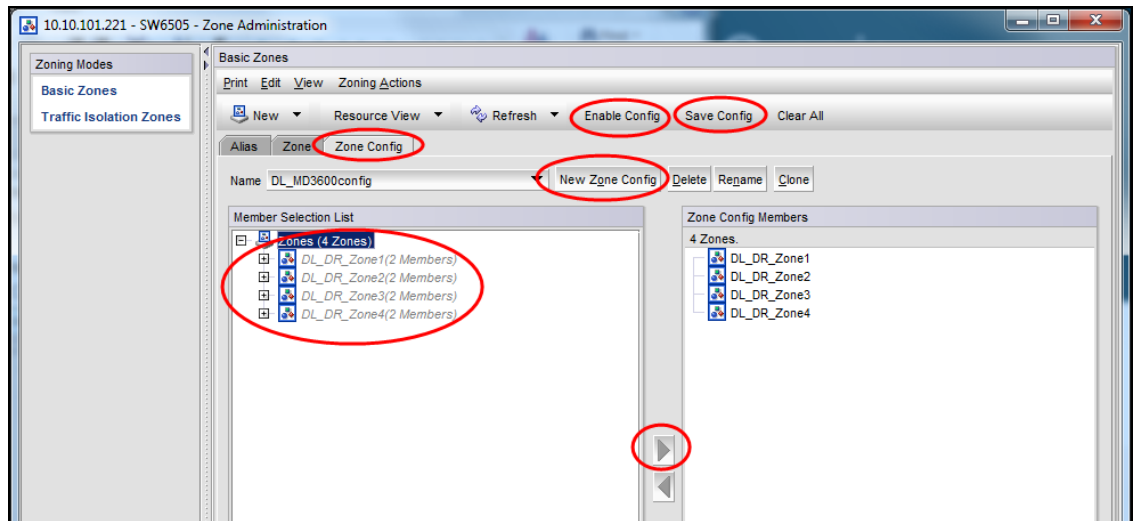

5. Repeat steps 1 - 4 to create and enable the four zones on the alternate fibre channel switch-2.

3.1.5 Create a Fibre Channel LUN to be assigned and used as a DL4X00 repository

- The DL4X00 high-capacity edition capacity points are 20, 40, 60 and 80TB. Create your fibre channel storage capacities according to your licensed capacity point.
- The fibre channel LUN capacity should be the same size as the licensed DL4X00 capacity.
- Configure the SAN storage using appropriate number of disks, speed and RAID and to support the recommended sustained throughput for your environment. The storage sizing recommendations are identified in the following AppAssure sizing matrix:

Number of Agents (physical and virtual)	CPU(1)	RAM- Server 2012 (2)	RAM- Server 2008 R2(3)	Network Cards	Repository Size(4)	Disk	Total Repository Size(5)	Application Assurance Triggers(6)	Change Rate Restrictions
Very Small 1-5 Agents	One dual-quad core processor	8GB	Add 2GB RAM per TB of repository space to Server 2012 Memory	1 Gigabit NIC	1.2 x total amount of data in all protected servers for Year 1. Each year add .5TB to accommodate growth	NAS, DAS, or SAN	0 - 2.5TB	1 SQL server/ 1 Exchange Any number of regular servers Max 10% SQL/EXCH Data Max 10% Virtual Standys	Total change rate across all agents < 10% daily and <20 GB/hr. Maximum size of a single incremental from any agent not to exceed 10 GB
Small 1 - 10 Agents	One quad-core processor, minimum E5-1400	8-16 GB	Add 2GB RAM per TB of repository space to Server 2012 Memory	2 x 1 Gigabit NIC in teamed mode.	1.2 x total amount of data in all protected servers for Year 1. Each year add .5TB to accommodate growth	NAS, DAS, or SAN	2.5 - 6TB	2 SQL servers 1 Exchange Any number of regular servers Max 10% SQL/EXCH Data Max 10% Virtual Standys	Total change rate across all agents < 10% daily and <20 GB/hr. Maximum size of a single incremental from any agent not to exceed 10 GB
Medium 11 - 20 Agents	One six-core processor, Intel E5-2400 or better.	16-32 GB	Add 2GB RAM per TB of repository space to Server 2012 Memory	2 x 1 Gigabit NIC in teamed mode.	1.2 x total amount of data in all protected servers for Year 1. Each year add .5TB to accommodate growth	DAS or SAN Sustained bandwidth of 200 MB/sec is strongly recommended.	6 - 12 TB	4 SQL servers 2 Exchange Any number of regular servers Max 10% SQL/EXCH Data Max 10% Virtual Standys	Total change rate across all agents < 10% daily and <75 GB/hr. Maximum size of a single incremental from any agent not to exceed 50 GB
Large 21 - 50 Agents	Minimum one six or eight core processor, Intel E5-2600 or better. Recommended 2 x six/eight-core processors	32-64GB	Add 2GB RAM per TB of repository space to Server 2012 Memory	4 x 1 Gigabit NIC in teamed mode, minimum. 10 Gigabit NIC recommended.	1.2 x total amount of data in all protected servers for Year 1. Each year add .5TB to accommodate growth	DAS or SAN EqualLogic storage or equivalent is strongly recommended. Sustained bandwidth of 300 MB/sec or higher	12 - 30 TB	8 SQL servers 4 Exchange Any number of regular servers Max 10% SQL/EXCH Data Max 10% Virtual Standys	Total change rate across all agents < 10% daily and <225 GB/hr. Maximum size of a single incremental from any agent not to exceed 75 GB
Enterprise 51 - 100 Agents	Two six or eight-core processors, 2 x E5-2600 or better.	64-128GB	Add 2GB RAM per TB of repository space to Server 2012 Memory	4 x 1 Gigabit NIC in teamed mode, minimum. 10 Gigabit NIC recommended.	1.2 x total amount of data in all protected servers for Year 1. Each year add .5TB to accommodate growth	DAS or SAN Compellent or EqualLogic storage or equivalent is strongly recommended Sustained bandwidth of 400 MB/sec or faster	> 30 TB	16 SQL servers 10 Exchange Any number of regular servers Max 10% SQL/EXCH Data Max 10% Virtual Standys	Total change rate across all agents < 10% daily and <400 GB/hr. Maximum size of a single incremental from any agent not to exceed 75 GB

Additional storage sizing details are outlined in [Knowledge Article 118407 - Sizing AppAssure 5 Deployments](#).



1. Open the MDSM storage management tool to configure the SAN storage.
2. Select **Create Storage** to create a LUN or configure Disk Pools or Disk Groups.

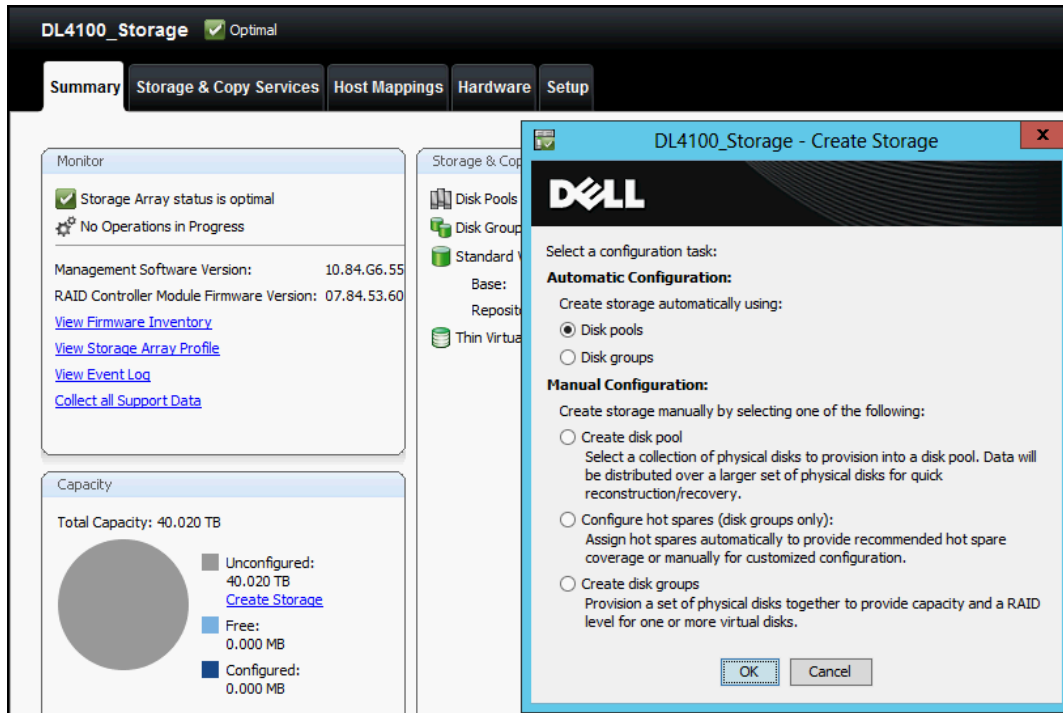

- a. Select **Yes** for the recommended configuration.
- b. Select **No** within the Virtual Disk Automatic Configuration window.
- c. Create a virtual disk. Select the **Storage & Copy Services** tab -> right click **Free Capacity** -> **Create Virtual Disk**.

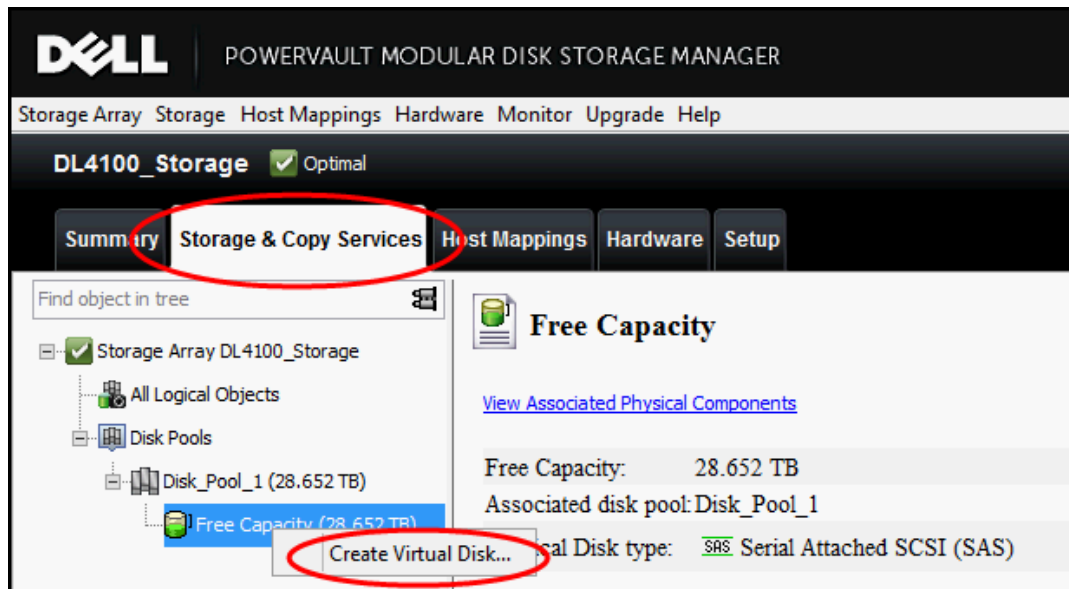

3. Define the capacity for the DL4X00 repository and name the LUN. Do not create a thin virtual disk. The newly created virtual disk capacity should be the same size as the licensed DL4X00 capacity.

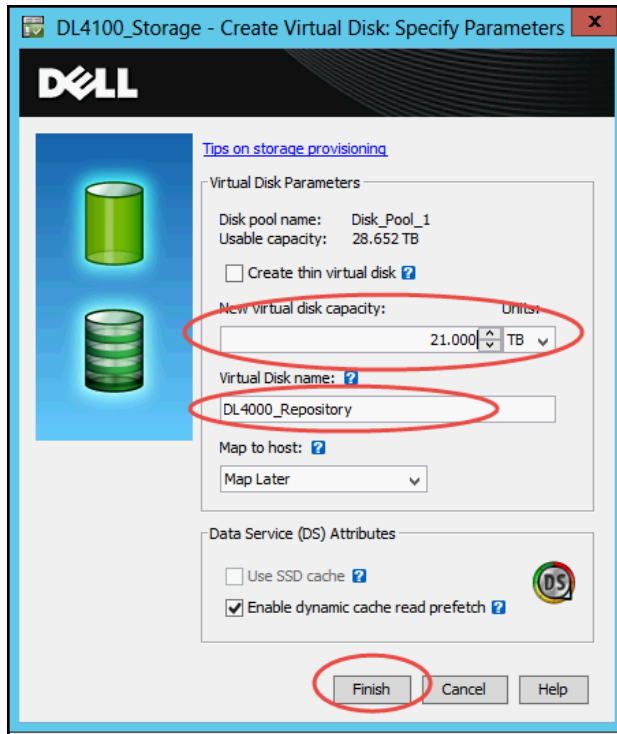

4. Assign the newly created LUN to the DL4X00:
 - a. Select the **Host Mappings** tab -> Right click the newly created LUN -> then select **Add LUN Mapping**.

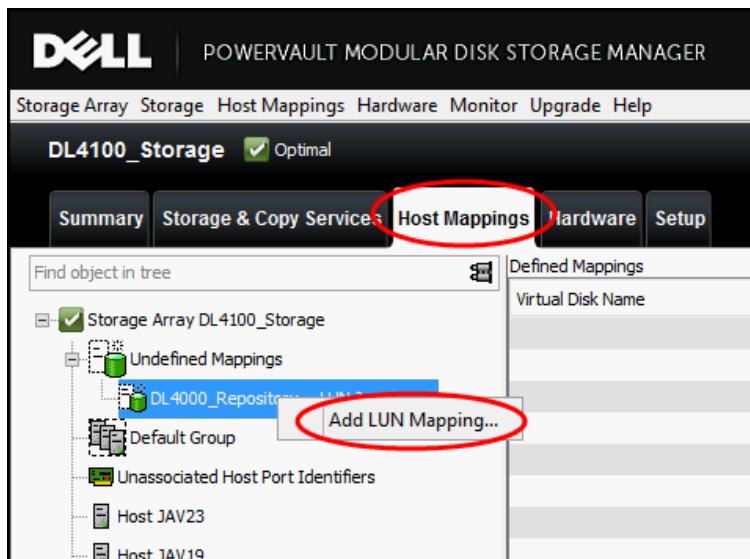

- b. Map the newly created LUN to the DL4X00. In this example, the DL4X00 is named Host JAV19. The newly created LUN is named DL4X00_Repository. Choose a logical unit number greater than 0.



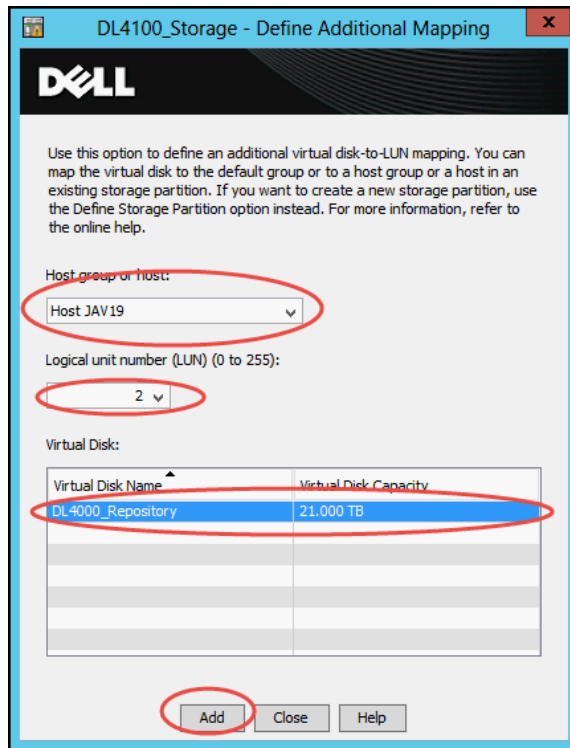

3.1.6 Mount the newly assigned fibre channel storage LUN to the DL4X00

1. At the DL4X00 desktop, launch **Server Manager** -> **File and Storage Services** -> **Disks**. Right-click the DL4X00 and choose **Rescan Storage**.

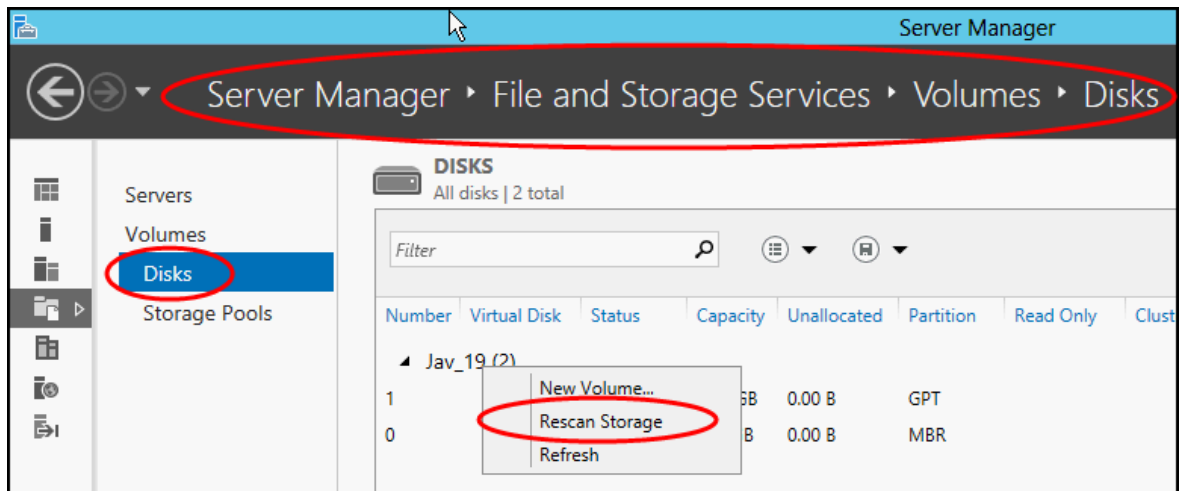

2. Right-click the newly added LUN and then choose **Bring Online**.

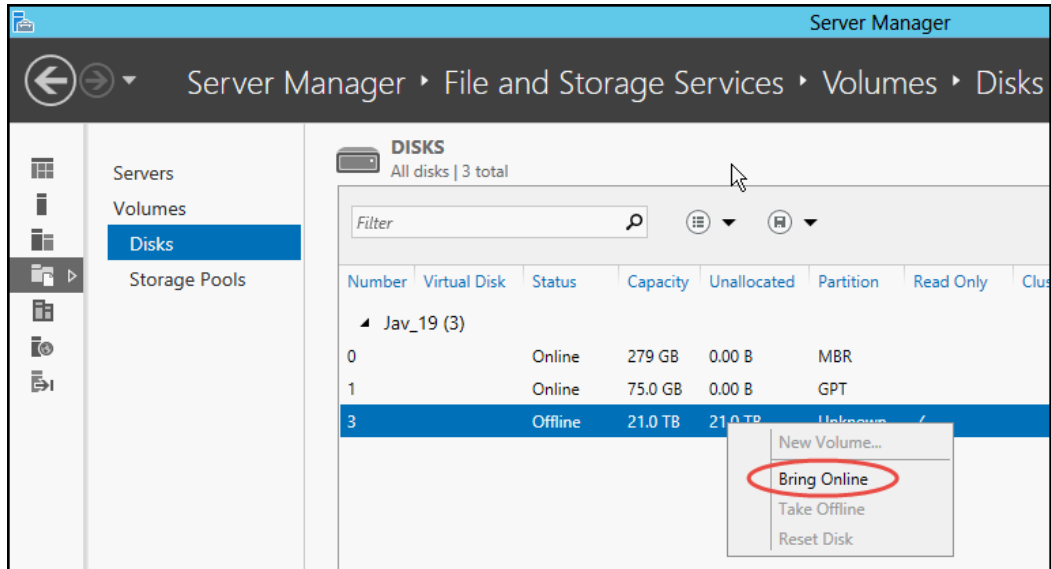

3. Initialize the LUN as a GPT disk.

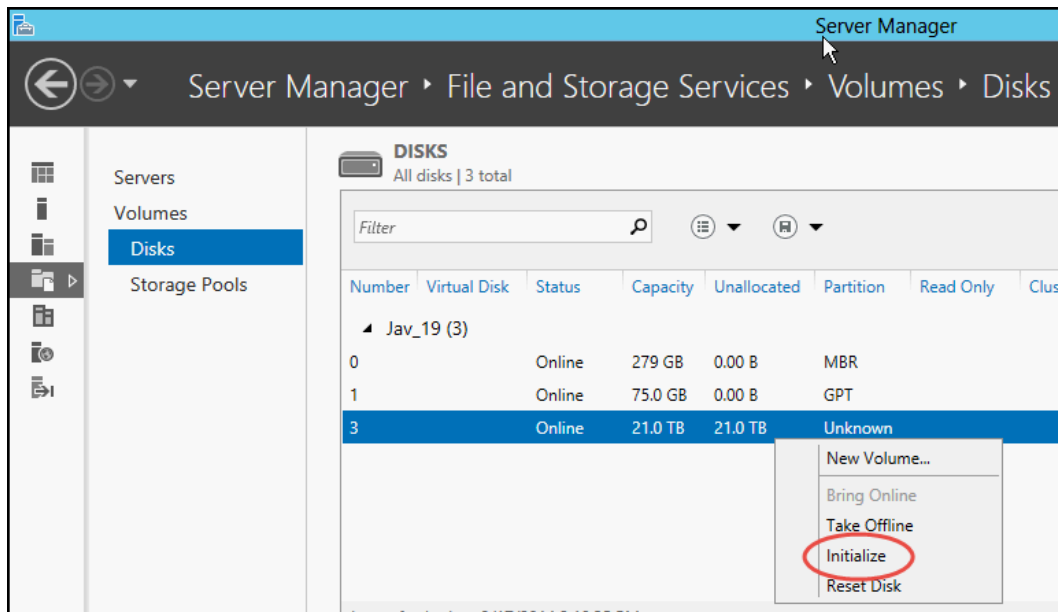

- Right-click **New Volume** to launch the New Volume Wizard. Use the default wizard settings and define a drive letter for the newly assigned LUN.

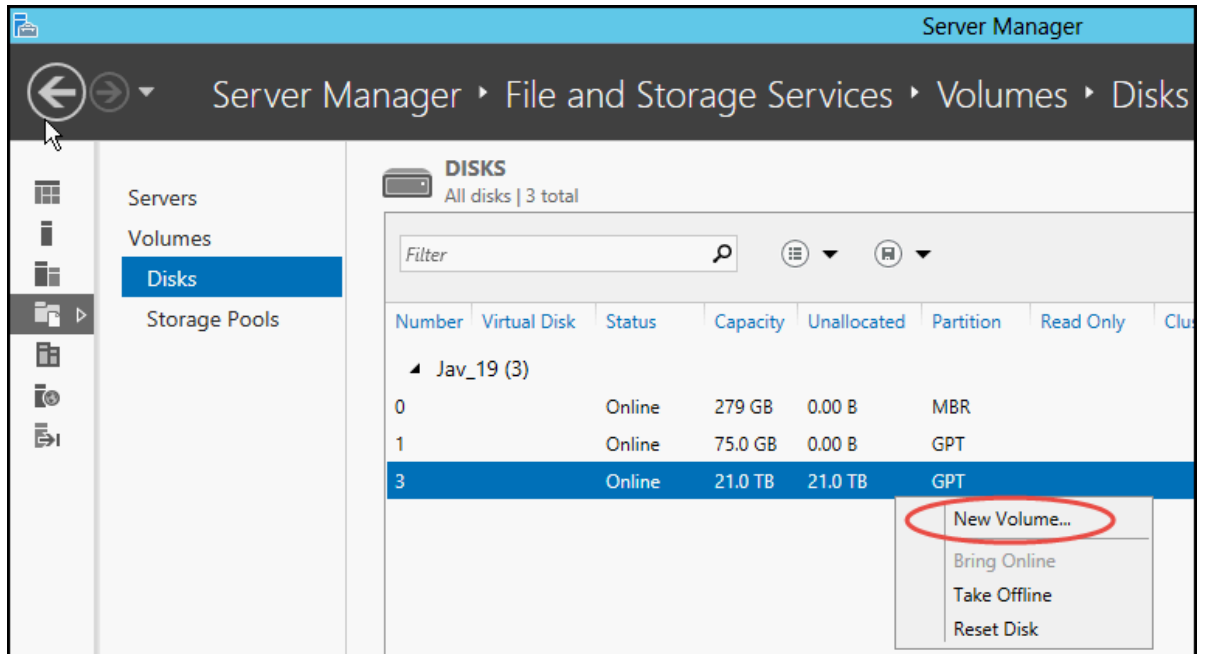

- When the New Simple Volume Wizard has been completed, the Volumes display should look similar to the display in the following image. The mounted fibre channel volume is ready to be configured for a DL4X00 repository.

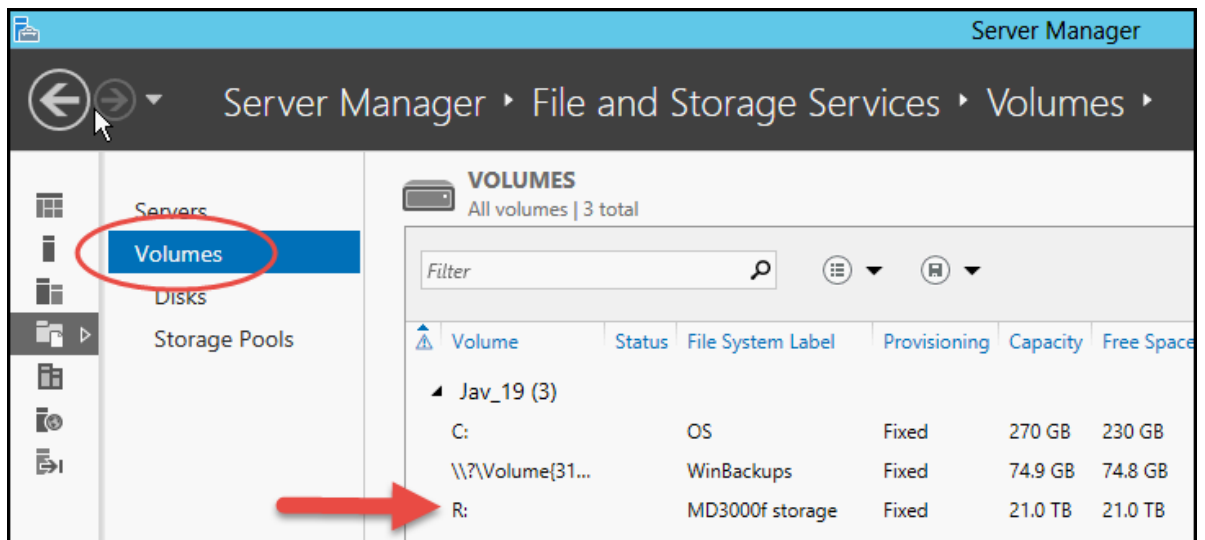

3.1.7 Configure the DL4X00 fibre channel storage as a backup repository

The following steps configure the fibre channel storage to be used by the DL4X00 as a repository. For additional DL4X00 repository creation details, please refer to [KB119910](#).

1. Launch the DL4X00 Core Console. Select **Configuration** -> **Repositories** -> **+ Add new** to begin the process of creating a new repository.

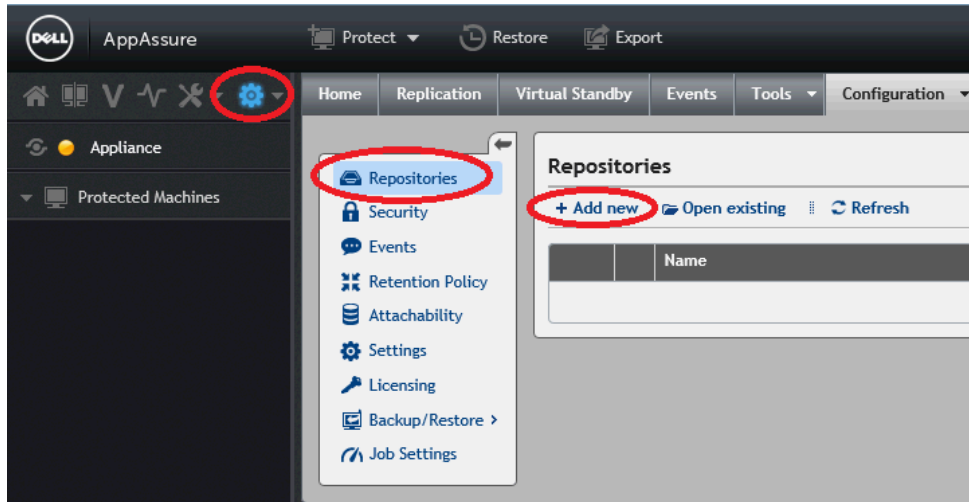

2. Select **+ Add Storage Location** to introduce the SAN storage for DL4X00 repository configuration.

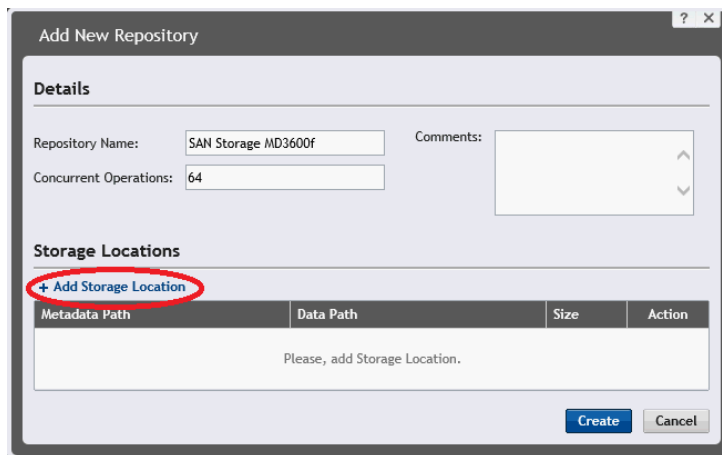

3. Select **Add file on local disk**. In this example, the DL4X00 \Data and \Metadata folders are configured to use the fibre channel storage identified by drive letter R. Select how much of the SAN LUN will be consumed by the repository (20, 40, 60 or 80TB capacities). Save the configuration.

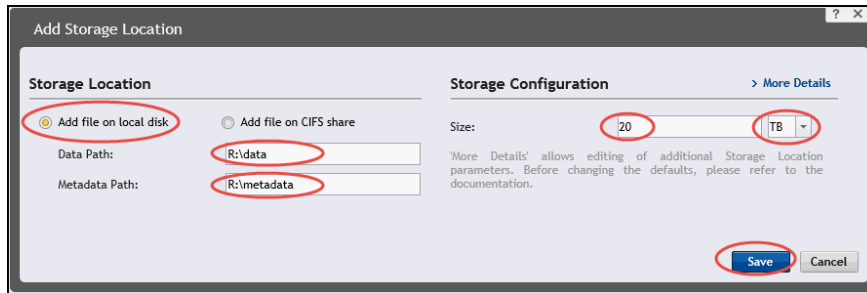

4. Select **Create** to add the new repository.

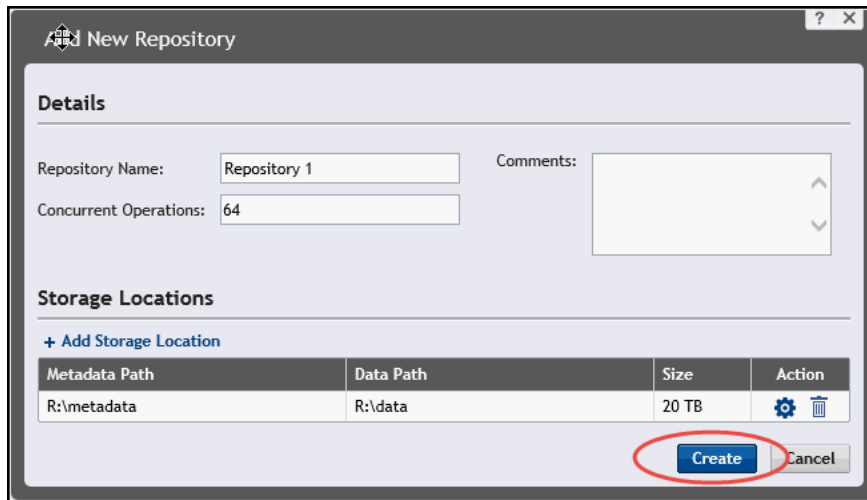

5. To confirm the repository has been created, select the **Configuration** tab. Select **Repositories**, and then select **Refresh**.

When the newly added fibre channel storage repository is displayed in the DL4X00 repository list, the process of adding fibre channel storage to the DL4X00 is finished.

